

AUTOOL[®]

AUTOOL BT250/BT260

Electrical System Tester

User Manual

用户手册

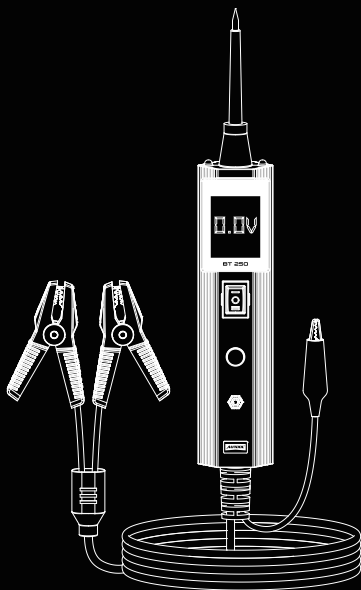

www.autooltech.com



深圳市偶然科技有限公司

广东省深圳市宝安区航城锦驰产业园

📍 Hangcheng Jinchí Industrial Park, Bao'an, Shenzhen, China

🌐 www.autooltech.com

✉ aftersale@autooltech.com

☎ +86-755-2330 4822 / +86-400 032 0988

执行标准 / Execution standard: GB/T8218-1987



COPYRIGHT INFORMATION

Copyright

- All rights reserved by AUTOOL TECH. CO., LTD. No part of this publication may be reproduced, stored in a retrieval system, or transmitted in any form or by any means, electronic, mechanical, photocopying, recording or otherwise, without the prior written permission of AUTOOL. The information contained herein is designed only for the use of this unit. AUTOOL is not responsible for any use of this information as applied to other units.
 - Neither AUTOOL nor its affiliates shall be liable to the purchaser of this unit or third parties for damages, losses, costs, or expenses incurred by the purchaser or third parties as a result of: accident, misuse, or abuse of this unit, or unauthorized modifications, repairs, or alterations to this unit, or failure to strictly comply with AUTOOL operating and maintenance instructions.
 - AUTOOL shall not be liable for any damages or problems arising from the use of any options or any consumable products other than those designated as original AUTOOL products or AUTOOL approved products by AUTOOL.
 - Other product names used herein are for identification purposes only and may be trademarks of their respective owners. AUTOOL disclaims any and all rights in those marks.
-

Trademark

Manual are either trademarks, registered trademarks, service marks, domain names, logos, company names or are otherwise the property of AUTOOL or its affiliates. In countries where any of the AUTOOL trademarks, service marks, domain names, logos and company names are not registered, AUTOOL claims other rights associated with unregistered trademarks, service marks, domain names, logos, and company names. Other products or company names referred to in this manual may be trademarks of their respective owners. You may not use any trademark, service mark, domain name, logo, or company name of AUTOOL or any third party without permission from the owner of the applicable trademark, service mark, domain name, logo, or company name. You may contact AUTOOL by visiting AUTOOL at <https://www.autooltech.com>, or writing to aftersale@autooltech.com, to request written permission to use materials on this manual for purposes or for all other questions relating to this manual.

TABLE OF CONTENTS

Cautions	1
Using The Test Tool	2
BT250 Tool description.....	2
BT260 Tool description.....	3
Specifications	4
General description	4
Power	4
Quick Self-Test	5
Circuit breaker	6
Work mode	6
Test Applications	9
Voltage & Polarity testing	9
Continuity testing.....	9
Signal circuit testing	11
Activating components in your hand.....	11
Test trailer and connection status.....	12
Activating components in the vehicle	13
Activating components with ground.....	14
Checking for bad ground contacts.....	15
Following & Locating short circuits	15
Red / Green polarity LED	16
Test Tool Specifications	17
Test Tool Know-How	18
Maintenance Service	20
Maintenance.....	20
Warranty	21
Warranty access.....	21
Disclaimer	21
Return & Exchange Service	22
Return & Exchange.....	22

CAUTIONS

Warning



Before using the instrument, please read this manual carefully for proper operation.

- ▶ Always perform automotive testing in a safe environment.
- ▶ Wear safety eye protection that meets ANSI standards.
- ▶ Keep clothing, hair, hands, tools, test equipment, etc. away from all moving or hot engine parts.
- ▶ Operate the vehicle in a well ventilated work area: Exhaust gases are poisonous.
- ▶ Put blocks in front of the drive wheels and never leave the vehicle unattended while running tests.
- ▶ Use extreme caution when working around the ignition coil, distributor cap, ignition wires and spark plugs. These components create dangerously high voltages when the engine is running.
- ▶ Put the transmission in PARK (for automatic transmission) or NEUTRAL (for manual transmission) and make sure the parking brake is engaged.
- ▶ Keep a fire extinguisher suitable for gasoline / chemical / electrical fires nearby.
- ▶ Don't connect or disconnect any test equipment while the ignition is on or the engine is running.
- ▶ Keep the tool dry, clean, free from oil / water or grease. Use a mild detergent on a clean cloth to clean the outside of the test tool, when necessary.
- ▶ When the power switch in the tool is depressed battery current/voltage is conducted directly to the tip which may cause sparks when contacting ground or certain circuits. Therefore the tool should NOT be used around flammables such as gasoline or its vapors. The spark of an energized tool could ignite these vapors. Use the same caution as you would when using an arc welder.

USING THE TEST TOOL

BT250 Tool description

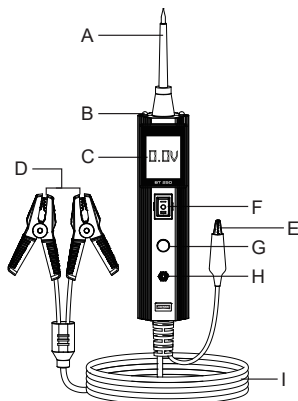

A	Probe Tip	Contacts the circuit or component to be tested.
B	Head Lights	Illuminates dark work areas or work areas at night.
C	LCD Display	Indicates test results.
D	Clamps	
E	Auxiliary Ground Clamps	Assists test as a ground lead.
F	Power Switch	Allows you to conduct a positive or negative battery current to the tip for activating and testing the function of electrical components.
G	Mode Button	Selects the work mode: AC voltage, DC voltage, resistance, tone.
H	Sound / Radiator	When the audio tone is turned on, a beep will be heard.
I	Power Cable	

BT260 Tool description

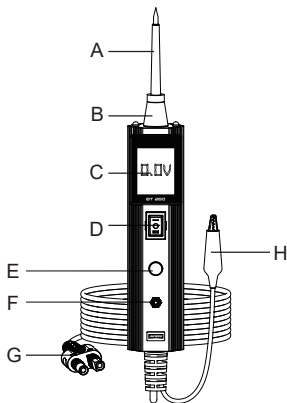

A	Probe Tip	Contacts the circuit or component to be tested.
B	Head Lights	Illuminates dark work areas or work areas at night.
C	LCD Display	Indicates test results.
D	Power Switch	Allows you to conduct a positive or negative battery current to the tip for activating and testing the function of electrical components.
E	Mode Button	Selects the work mode: AC voltage, DC voltage, resistance, tone.
F	Sound / Radiator	When the audio tone is turned on, a beep will be heard.
G	Adaptor	Connects to the battery.
H	Auxiliary Ground Clamps	Assists test as a ground lead.

Specifications

Display	TFT color display (160x128dpi)
Operating Temperature	0~60°C (32~140°F)
Storage Temperature	-40~70°C (-40~185°F)
External Power	12.0 or 24.0V power provided via vehicle battery
Length	126mm (4.96")
Width	46.5mm (1.83")
Height	35mm (1.38")
NW	0.105kg (0.23lb)
GW	0.726kg(1.6lb)

General description

The tool is the best electrical tester for reducing diagnostic time in all 6 to 30 volt vehicle electrical systems. After a simple hook-up of the tool to the vehicle's battery, you can:

- Determine at a glance if a circuit is positive, negative, or open without having to reconnect clips from one battery pole to another.
- Test for continuity with its built-in auxiliary ground lead.
- By depressing the power switch, conduct a positive or negative battery current to the probe tip for testing the function of an electrical component without the use of jumper wires.
- Test for poor ground contacts instantly without performing voltage drop tests. The tool is also short-circuit protected; its internal circuit breaker will trip if it becomes overloaded.
- Follow and locate short circuits without wasting fuses.

Power

The tool is powered via the vehicle battery. Connect the RED battery clamp to the POSITIVE terminal of the vehicle's battery, and the BLACK clamp to the NEGATIVE terminal. When the tool is first connected to a battery (power source), it will sound a beep and the Head Lights will be on to illuminate the test area of the probe tip.

Quick Self-Test

- Before you test a circuit or component, be sure your tool is in good order by doing a quick self-test.
- With the tool connected, perform a quick self-test. The power switch is a momentary rocker switch located on the tool's body. Flanking the switch are positive and negative markings.
- Press the Power Switch forward to activate the tip with a positive voltage. The Red LED should light and the LCD display will read the battery voltage. If the tone feature is turned on, a high pitched tone will sound. Let go of the power switch and the LED will turn off and the high tone will cease.
- Press the Power Switch rearward to activate the tip with a negative voltage. The Green LED should light and the LCD display will read the "0.0V" (ground). If the tone feature is turned on, a low pitched tone will sound. Let go of the power switch and the LED will turn off and the low tone will cease.
- Your tool is working correctly and is now ready for use.

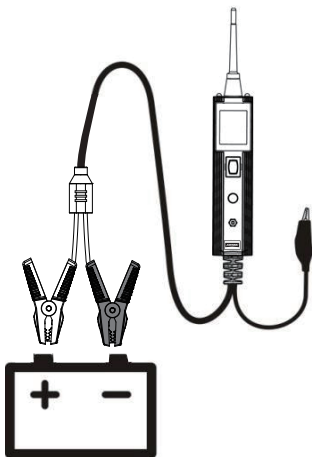

IMPORTANT:

- ▶ When powering-up components, you can increase the life of power switch in the tool if you first press the switch, then contact the tip to the component. The arcing will take place at the tip instead of the contacts of the switch.

Circuit breaker

This product has automatic short circuit protection, its internal overload protection system will automatically break the circuit and restart it in the event of an overload or short circuit.

When the circuit is overloaded, a restart screen appears on the screen without damaging the unit, meaning you can still use functions such as circuit detection and observation of voltage values.

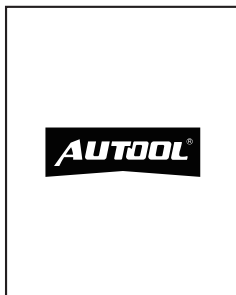
**Work mode**

There are four modes to diagnose the electrical systems, which can be accessed by depressing the Mode Button and cycling through each one.

DC voltage

- While the tool in this mode, contact the probe tip to a circuit, then the LCD display will read the DC voltage with a resolution of 0.1 volt.



AC voltage

- While the tool in this mode, contact the probe tip to a circuit, then the LCD display will read the Max. voltage, the Min. voltage, frequency and duty cycle.

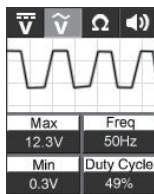

Resistance

- While the tool in this mode, contact the probe tip to a circuit, then the LCD display will read the resistance between the tip and auxiliary ground lead.



Tone On / Off

- While the tool in this mode, just do a quick press of the mode button to toggle the tone on or off. While quickly pressing (a quick press and release) the mode button, if a short high beep is heard, this means the audio tone is turned on. If a short low beep is heard, the audio tone is turned off.
- This function is invaluable when working in bright areas where LED illumination alone is not sufficient. The audio feature may be disengaged when desired, such as for applications where the tool will be connected to circuits for long periods of time and the audio could become annoying.

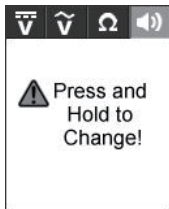

TEST APPLICATIONS

Voltage & Polarity testing

- While the tool is in DC Voltage mode, contact the probe tip to a POSITIVE circuit. The red LED will light and the LCD displays the voltage with a resolution of 0.1V. If the beep is turned on, a high pitched tone will sound.
- If contact the probe tip to a NEGATIVE circuit, the green LED will light and the LCD displays the voltage with a resolution of 0.1V. If the beep is turned on, a low pitched tone will sound.
- If contact the probe tip to an OPEN circuit, neither of the LED will light.

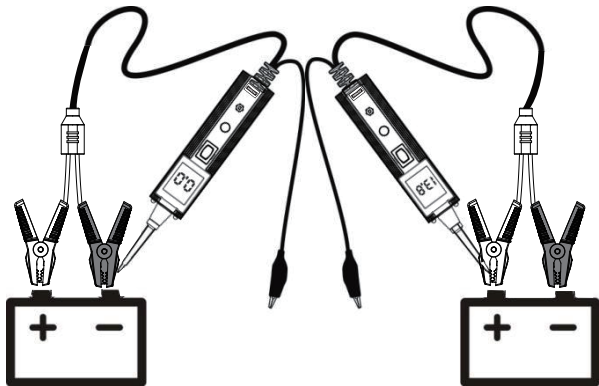

Continuity testing

- While the tool is in Resistance mode, using the probe tip with chassis ground or the auxiliary ground lead, continuity can be tested on wires and components attached or disconnected from the vehicle's electrical system.
- When the probe tip is contacting a good ground, the LCD will indicate "0.0Ω" and green LED will be on. If the tone feature is turned on, a low pitched tone will sound.

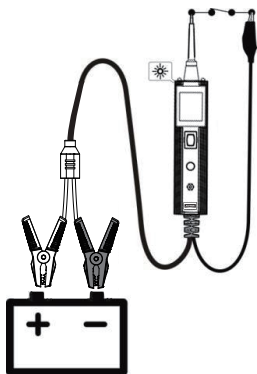

- In other cases, the LCD only indicates the resistance value.



- If the resistance value is greater than $200\text{k}\Omega$, the LCD will show "OL".

There is also another way to prove continuity of connections to ground or battery. Power up the connection using the power switch. If the circuit breaker trips you know that you have a good solid low resistance connection.

⚠ NOTE:

- ▶ You can use the probe tip to pierce the plastic insulation on a wire. This means that you can test the circuit without disconnecting anything.

Signal circuit testing

Once you extract a DTC from the vehicle and realize that trouble-shooting begins with some kind of sensor circuit, there is a quick test you can perform to verify the code.

Testing your sensor is easy while using the tool. For example, you suspect there is a problem with your M.A.P. Sensor circuit, then follow the procedure involved with testing this sensor:

- Set the tool in AC Voltage mode, using the probe tip with chassis ground or the auxiliary ground lead.
- Connect vacuum pump to MAP sensor.
- Contact the probe tip to the MAP sensor positive terminal and observe the LCD readings which should be a sine wave in normal condition.
- Apply vacuum.
- Release vacuum and observe the LCD readings.

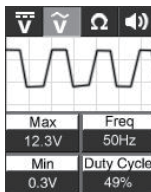

► If the LCD readings are abnormal, there is a problem with this sensor.

Activating components in your hand

While the tool is in DC Voltage mode, by using the probe tip in connection with the auxiliary ground lead, components can be activated right in your hand, thereby testing their functions.

Connect the auxiliary ground lead to the negative terminal or ground side of the component being tested. Then contact the probe tip to the positive terminal of the component, the green LED should light, indicating continuity through the component. While keeping an eye on the green LED, quickly press and release the power switch forward. If the green LED went out and the red LED came on, you may proceed with further activation. Rock the power switch forward and hold it down to provide power

to your component. With the power switch rocked forward, power will flow from the positive lead on the battery into the probe tip, through the tip into the component's positive terminal, into the component and out of the component, through the auxiliary ground lead and back into the tool, and back to the vehicle battery's ground.

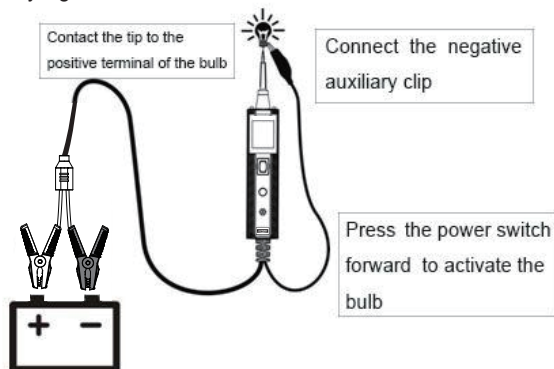

If the green LED went off at that instant or if the circuit breaker tripped, the tool has been overloaded. This could happen for the following reasons:

- The contact you are probing is a direct ground or negative voltage.
- The component you are testing is short-circuited.
- The component is a very high current component (i.e., starter motor).

If the circuit breaker is tripped, reset it by waiting for it to cool down (15 sec.) and then depressing the reset button.

Test trailer and connection status

Connect the ground auxiliary wire to the ground of the trailer lights when in DC voltage mode, and insert the probe into the OBD pin to display the real-time voltage. By using this method it is possible for you to check the function and direction of the

connector and trailer lights. If the circuit breaker trips, please wait for 15 seconds for it to cool down and then it will automatically reset, then press the reset button until it snaps into place.

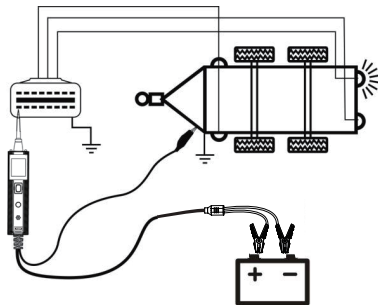

Activating components in the vehicle

While the tool in DC Voltage mode, contact the probe tip to the positive terminal of the component, the green LED should light, indicating continuity to ground. While observing the green LED, quickly depress and release the power switch forward. If the green LED went out and the red LED came on, you may proceed with further activation. If the green LED went off at that instant or if the circuit breaker tripped, the tool has been overloaded. This could happen for the following reasons:

- The contact you are probing is a direct ground.
- The component you are testing is short-circuited.
- The component is a very high current component (i.e., starter motor).

If the circuit breaker is tripped, reset it by waiting for it to cool down (15 sec.) and then depressing the reset button.

⚠ WARNING:

- ▶ Haphazardly applying voltage to certain circuits can cause damage to a vehicle's electronic components. Therefore, it is strongly advised to use the vehicle manufacturer's schematic and diagnosing procedure while testing.

⚠ NOTE:

- ▶ When powering up components, you can increase the life of power switch if you first press the switch, then contact the tip to the component. The arcing will take place at the tip instead of the contacts of the switch.

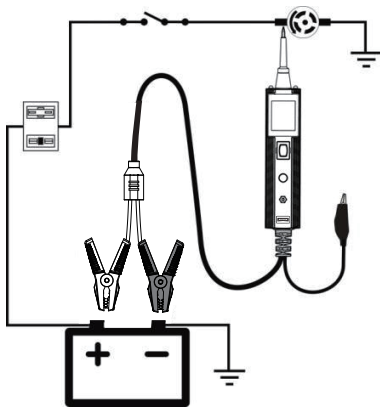

Activating components with ground

While the tool in DC Voltage mode, contact the probe tip to the negative terminal of the component, the red LED should light. While observing the red LED, quickly depress and release the power switch rearward. If the red LED went out and the green LED came on, you may proceed with further activation. If the green LED went off at that instant or if the circuit breaker tripped, the tool has been overloaded. This could happen for the following reasons:

- The contact you are probing is a direct positive voltage.
- The component you are testing is short-circuited.
- The component is a very high current component (i.e., starter motor).

If the circuit breaker is tripped, reset it by waiting for it to cool down (15 sec.) and then depressing the reset button.

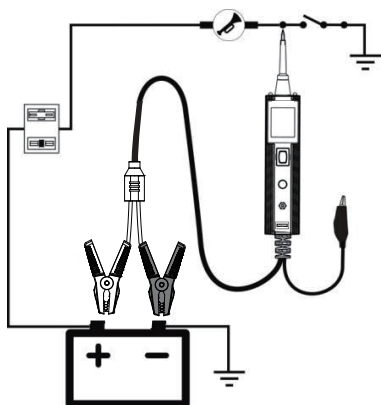

- With this function, if you are contacting a protected circuit, a vehicle's fuse can be blown or tripped if you apply ground to it.

Checking for bad ground contacts

Probe the suspected ground wire or contact with the probe tip.

- Observe the green LED. Depress the power switch forward then release. If the green LED went out and the red LED came on, this is not a true ground.
- If the circuit breaker tripped, this circuit is more than likely a good ground. Keep in mind that high current components such as starter motors will also trip the circuit breaker.

Following & Locating short circuits

In most cases a short circuit will appear by a fuse or a fusible link blowing or an electrical protection device tripping (i.e., a circuit breaker). This is the best place to begin the search.

- Remove the blown fuse from the fuse box.
- Use the probe tip to activate and energize each of the fuse contacts. The contact which trips the circuit breaker is the

shorted circuit. Take note of this wire's identification code or color.

- Follow the wire as far as you can along the wiring harness. Here is an example for this application.
- If you are following a short in the brake light circuit, you may know that the wire must pass through the wiring harness at the door sill. Locate the color coded wire in the harness and expose it.
- Probe through the insulation with the probe tip, and depress the power switch forward to activate and energize the wire.
- If the circuit breaker tripped, you have verified the shorted wire. Cut the wire and energize each end with the probe tip. The wire end which trips the circuit breaker again is the shorted circuit and it will lead you to the shorted area.
- Follow the wire in the shorted direction and repeat this process until the short is located.

Red / Green polarity LED

- The Red / Green Polarity LED lights up when the probe tip voltage matches the battery voltage within ± 0.8 volts. It is added information that could be valuable to the technician.
- If the circuit you are testing is not within a 0.8 volt (plus or minus) of supply voltage, you will see the voltage reading on the LCD but you will not hear a tone or see a red or green LED. This tells you either you have a voltage drop in excess of 0.8 volt from battery voltage or you are probing a circuit that has an increase of a 0.8 volt or more over battery voltage.
- To determine battery voltage, simply remove the tip from the circuit and press the power switch forward. Battery voltage will then be displayed on the LCD. The difference between the battery voltage and what is read on the circuit is either voltage drop or voltage increase. This allows you to determine a voltage drop without running back to check the battery. It's just another one of time saving feature the tool has.

TEST TOOL SPECIFICATIONS

DC voltage range	0~65V +1
AC voltage range	0~65V +1
Resistance range	0~200KΩ
Frequency response of tone pass through	0Hz~10KHz
Circuit breaker rating current	1~10Amp

Testing Standard	
100% current	no trip
150% current	trip in one hour
200% current	trip in 3~30 seconds
300% current	trip in 0.5~4.0 seconds

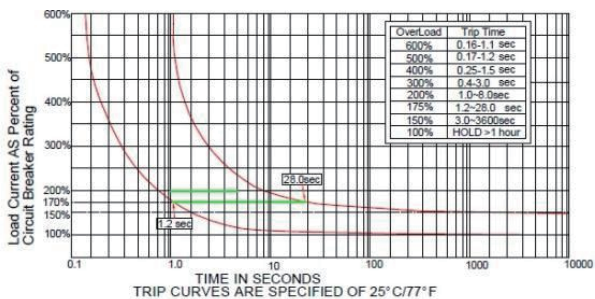

TEST TOOL KNOW-HOW

Is the Power Scan Probe Tester computer and air bag safe?

- The tool LED and LCD pull no more than 1 milliamp of current, therefore when using it as a test light or multimeter it is computer and airbag safe. However, pressing the power switch is a different story. When you press the switch forward, you are conducting full battery current to the tip of the probe. There is a nice safety feature built into the tool. Simply connect the extra ground lead to the tool and press the power switch forward until it trips the circuit breaker. This will prevent power from going to the tip but still allow you to use the tool as a multimeter. When you are away from computer components, simply press the reset button and you are ready to power up again.

Why do I have no power at the tip when I am pressing the power switch forward but the red LED is on?

- The power switch goes through a lot. It is one of the few things that go wrong with the tool. The switch is a consumable that needs to be replaced on occasion. We have made it real simple to not only change it but also buy a new switch. The switch can be snapped out and replaced in seconds.
 - You can buy switches from your authorized tool supplier.
 - The tool with the Rocker Switch slots makes it easy to replace a worn switch in the field without having to send it in for repair. Power Switch replacement procedure:
- ① Remove the worn switch with a pry tool. Be careful when applying force.

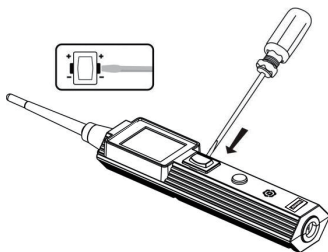

- ② Make sure to install the switch straight and press until flush with casing

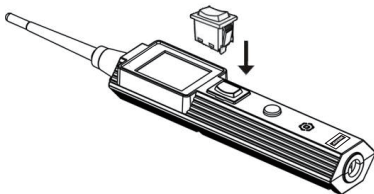

It is recommended when buying you get two. This will fix your tool now and give you a spare so you won't experience any down time in the future.

MAINTENANCE SERVICE

Our products are made of long-lasting and durable materials, and we insist on perfect production process. Each product leaves the factory after 35 procedures and 12 times of testing and inspection work, which ensures that each product has excellent quality and performance.

Maintenance To maintain the performance and appearance of the product, it is recommended that the following product care guidelines be read carefully:

- Be careful not to rub the product against rough surfaces or wear the product, especially the sheet metal housing.
- Please regularly check the product parts that need to be tightened and connected. If found loose, please tighten it in time to ensure the safe operation of the equipment. The external and internal parts of the equipment in contact with various chemical media should be frequently treated with anti-corrosion treatment such as rust removal and painting to improve the corrosion resistance of the equipment and extend its service life.
- Comply with the safe operating procedures and do not overload the equipment. The safety guards of the products are complete and reliable.
- Unsafe factors are to be eliminated in time. The circuit part should be checked thoroughly and the aging wires should be replaced in time.
- Adjust the clearance of various parts and replace worn (broken) parts. Avoid contact with corrosive liquids.
- When not in use, please store the product in a dry place. Do not store the product in hot, humid, or non-ventilated places.

WARRANTY

From the date of receipt, we provide a three-year warranty for the main unit and all the accessories included are covered by a one-year warranty.

Warranty access

- The repair or replacement of products is determined by the actual breakdown situation of product.
- It is guaranteed that AUTOOL will use brand new component, accessory or device in terms of repair or replacement.
- If the product fails within 90 days after the customer receives it, the buyer should provide both video and picture, and we will bear the shipping cost and provide the accessories for the customer to replace it free of charge. While the product is received for more than 90 days, the customer will bear the appropriate cost and we will provide the parts to the customer for replacement free of charge.

These conditions below shall not be in warranty range

- The product is not purchased through official or authorized channels.
- The product breakdown because the user does not follow product instructions to use or maintain the product.

We AUTOOL pride ourselves on superb design and excellent service. It would be our pleasure to provide you with any further support or services.

Disclaimer

All information, illustrations, and specifications contained in this manual, AUTOOL reserves the right of modify this manual and the machine itself with no prior notice. The physical appearance and color may differ from what is shown in the manual, please refer to the actual product. Every effort has been made to make all descriptions in the book accurate, but inevitably there are still inaccuracies, if in doubt, please contact your dealer or AUTOOL after-service centre, we are not responsible for any consequences arising from misunderstandings.

RETURN & EXCHANGE SERVICE

Return & Exchange

- If you are an AUTOOL user and are not satisfied with the AUTOOL products purchased from the online authorized shopping platform and offline authorized dealers, you can return the products within seven days from the date of receipt; or you may exchange it for another product of the same value within 30 days from the date of delivery.
- Returned and exchanged products must be in fully saleable condition with documentation of the relevant bill of sale, all relevant accessories and original packaging.
- AUTOOL will inspect the returned items to ensure that they are in good condition and eligible. Any item that does not pass inspection will be returned to you and you will not receive a refund for the item.
- You can exchange the product through the customer service center or AUTOOL authorized distributors; the policy of return and exchange is to return the product from where it was purchased. If there are difficulties or problems with your return or exchange, please contact AUTOOL Customer Service.

China	400-032-0988
Oversea Zone	+86 0755 23304822
E-mail	aftersale@autooltech.com
Facebook	https://www.facebook.com/autool.vip
YouTube	https://www.youtube.com/c/autooltech

目录

版权信息	25
版权	25
注册商标	25
注意事项	26
警告	26
产品简介	27
概述	27
产品规格	27
特征	27
产品结构	28
BT250 结构图	28
BT260 结构图	29
产品使用	30
电源	30
快速自检	30
自动断路器	31
工作模式	31
测试应用	34
电压与正负极测试	34
连续性测试	34
信号电路测试	36
激活手中部件	36
测试拖车灯和连接状态	37
激活车上部件	38
激活部件/接地	39
检查地线不良接触	40
追踪和定位短路电路	40
红绿LED指示灯	41

规格参数	42
常见问题.....	43
维修保养服务.....	45
维修保养	45
保修服务	46
保修方式.....	46
声明	46
退换货服务	47
退换货	47

版权信息

版权

- 版权所有! 未征得深圳市偶然科技有限公司的书面同意, 任何公司或个人不得以任何形式(电子、机械、影印、录制或其他形式)对本说明书进行复制和备份。本手册专为偶然公司产品的使用而计, 对于将之用于指导其他设备操作而导致的各种后果, 本公司不承担任何责任。
 - 因使用者个人或第三方的意外事故, 滥用、误用该设备, 擅自更改, 或修理该设备, 或未按偶然公司的操作与保养要求而导致设备损坏、遗失所产生的费用及开支等, 偶然公司及其分支机构不承担任何责任。
 - **正式声明:** 本说明书所提及之其他产品名称, 目的在于说明该设备如何使用, 其注册商标所有权仍属原公司。
 - 本设备供专业技术人员或维修人员使用。
-

注册商标

偶然公司已在中国及海外若干国家进行了商标注册, 其标志为 **AUTOTOL**。本手册所提及之偶然公司其它商标、服务标志、域名、图标、公司名称均属偶然及其下属公司之产权。在偶然公司之商标、服务标志、域名、图标、公司名称还未注册之国家, 偶然公司声明其对未注册商标、服务标志、域名、图标、公司名称之所有权。本手册所提及之其它产品及公司名称的商标仍属于原注册公司所有。在未得到拥有人的书面同意之前, 任何人不得使用偶然公司或所提及的其它公司之商标、服务标志、域名、图标、公司名称。

您可以访问偶然网址: www.autooltech.com, 或发送邮件至: aftersale@autooltech.com, 与偶然公司进行联系, 征得其手册使用权之书面同意。

注意事项

警告

⚠ 使用仪器前，请仔细阅读本手册以正确操作。

- ▶ 请确保在一个安全的环境中执行诊断测试或服务。
- ▶ 佩戴符合ANSI标准的安全保护眼镜。
- ▶ 将衣服、头发、手、工具、测试设备等远离所有正在运行或发热的设备。
- ▶ 由于测试时排出的废气有毒，请在通风良好的工作区测试车辆。
- ▶ 请在车轮底部放置阻块，勿在车辆处于无人看管的状态下测试。
- ▶ 在点火线圈周围工作时，要特别小心分器盖、点火导线和火花塞。这些组件在发动机运转时会产生危险高压。
- ▶ 在汽油/化学/电气装置附近放置灭火器以防发生火灾。
- ▶ 把变速箱档位挂停车挡（自动变速器）或空挡（手动变速器）并确保拉上手刹。
- ▶ 在点火开关打开或发动机运转时，请勿连接或断开任何测试设备。
- ▶ 当按压工具的电源开关，电池电流、电压会被直接传导到接触地面或某些电路，可能会产生火花。因此，请勿在易燃物，如汽油或其蒸气附近使用。通电工具的火花会引燃这些蒸气，所以请采取使用电焊机时同样的操作方式以确保安全。
- ▶ 保持设备干燥、清洁，无油、水或油脂。必要时请使用干净的布清洁设备。

产品简介

概述

本产品是应用于快速测试所有6V-30V汽车电路系统的工具，具有快速查找车辆短路位置等功能，是一款高效先进的测试工具，能够大大提高用户的工作效率。

产品规格

显示屏	TFT 真彩显示屏 (160*128DPI)	
工作温度	0~60°C (32~140°F)	
贮藏温度	-40~70°C (-40~185°F)	
外接电源	12V或24V汽车蓄电池供电	
尺寸	长度	126mm
	宽度	46.5mm
	高度	35mm
净重	0.105kg	
毛重	0.726kg	

特征

- 无需连接电瓶夹到另外一端，一眼就能分辨出电路是正极还是负极。
- 用其自带的辅助接地导线进行连续性测试。
- 通过按压电源开关，控制探头探针以识别电流的正负极。当测试电气组件功能时，无需使用跳线。
- 检查接地不良接触导线，无需执行压降步骤。
- 本产品还具有短路保护功能，若过载导致其内部的电路断路器自动跳闸，本产品可以自动复位。
- 在无需浪费保险丝的条件下能够方便快速地查找出短路位置。

产品结构

BT250
结构图

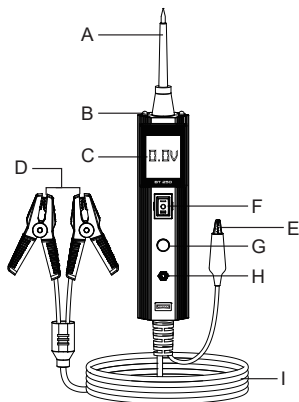

A	探针	接触线路或部件进行测试。
B	LED灯	在黑暗的工作区或夜间工作时提供照明。
C	液晶显示屏	用于显示测试结果。
D	电源夹	
E	接地夹	接地引线辅助测试功能。
F	电源开关	用于激活和测试电器元件的功能进行的一个正极或负极的电池电流探针引导。
G	模式按钮	选择工作模式: 交流电压、直流电压、电阻、蜂鸣器。
H	蜂鸣器	发出蜂鸣用于警告或提示。
I	电源线	

BT260
结构图

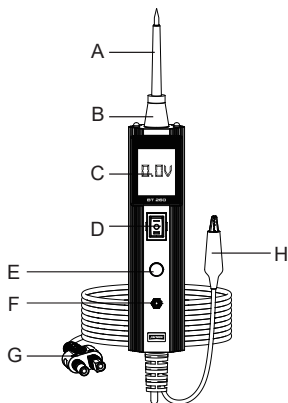

A	探针	接触线路或部件进行测试。
B	LED灯	在黑暗的工作区或夜间工作时提供照明。
C	液晶显示屏	用于显示测试结果。
D	电源开关	用于激活和测试电器元件的功能进行的一个正极或负极的电池电流探针引导。
E	模式按钮	选择工作模式：交流电压、直流电压、电阻、蜂鸣器。
F	蜂鸣器	发出蜂鸣用于警告或提示。
G	适配器	连接蓄电池夹到汽车蓄电池或延长线。
H	接地夹	接地引线辅助测试功能。

产品使用

电源

本产品通过汽车蓄电池供电，将红色蓄电池钳夹到汽车蓄电池的正极，黑色蓄电池钳夹到汽车蓄电池的负极。当第一次使用本产品时，将蓄电池钳连接到蓄电池之后，蜂鸣器会发出哔的声音，然后LED灯会照亮探针的测试区域。

快速自检

在开始测试电路或者部件之前，请通过自检来确认您的设备是否处于完好状态。首先将设备连接，进行快速自检。需要注意的是：电源开关是一个瞬时翘板开关，位于主机正上方，开关的一测有正负极标记。向前按下电源开关后会激活带有正极电压的探针，接着红色LED指示灯也会亮起，继而液晶屏上将会显示出电池电压。如果提示音功能已经开启，提示音就会响起。关闭电源开关，指示灯熄灭，声音停止。

- 接着向后按下电源开关激活带有负电压的探针，绿色LED会亮起并在液晶屏上显示0.0V。如果提示音功能已经开启，提示音就会响起。关上电源开关，指示灯将熄灭，声音停止。
- 如果通过以上测试，表示该设备可正常工作，随时可以准备使用（如图）。

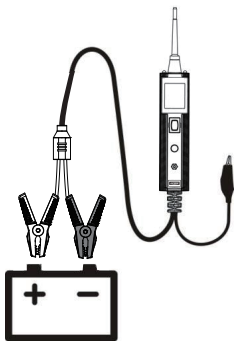

⚠ 注意

- ▶ 在设备供电的时候，您可以通过先按压开关，然后再将探针接触组件的方法来延长开关的使用寿命。

自动断路器

本产品具有短路自动保护功能，如果过载，或短路，其内部过载保护系统会自动断路重启。

- 当电路过载时，屏幕会出现重启开机界面，设备开机后其它功能依然可以正常使用，这意味着您仍然可以使用电路探测，观察电压数值等功能。

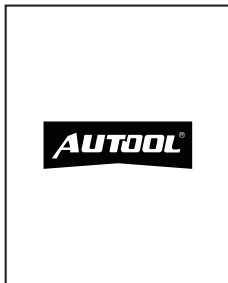
**工作模式**

本产品共有四种模式来诊断电路系统，您可以通过使用模式按钮来相互切换，循环显示。

直流电压

- 当设备处于本模式下，将探针接触到电路，屏幕便会显示0.1V误差的电压数值。



交流电压

- 当设备处于本模式下, 将探针接触到电路, 屏幕便会显示及时读出的最大电压伏数、最小电压伏数、频率以及占空比等信息。

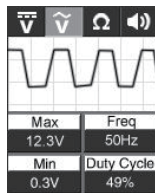

电阻

- 当设备处于本模式下, 将探针接触到电路, 屏幕便会显示及时读出的探针和辅助接地线之间的电阻阻值。



蜂鸣器开关

- 当设备处于本模式下，通过长按模式按键来开启/关闭声音功能。当长按模式按钮（按压后松开按钮）后，听到长蜂鸣声，则表示声音功能开启。若听到短蜂鸣声，则表示声音功能关闭。
- 此功能用于产品在高亮环境下，LED的照明功能被弱化时启用。当您长时间测试时，蜂鸣器发出的声音可能会使人烦躁，因此蜂鸣器的提示音可以在必要时关闭。



测试应用

电压与正负极测试

- 当设备处于直流电压模式时，将探针接触到正极电路，此时红色的LED指示灯便会亮起，并且屏幕会显示0.1V误差的电压数值。如果提示音功能已经开启，蜂鸣器会同时发出长提示音。
- 如果探针接触到负极电路，此时绿色的LED指示灯便会亮起，并且屏幕会显示0.1V误差的电压数值。如果提示音功能已经开启，蜂鸣器会同时发出短提示音。
- 如果探针接触到开路，两个LED提示灯都不会点亮。

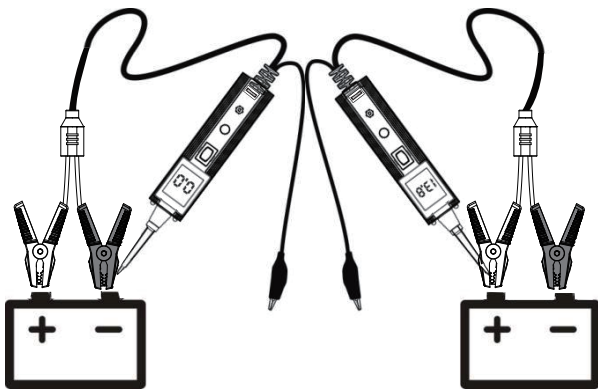

连续性测试

- 当设备处于电阻模式时，将探针接触汽车底盘或接地辅助线，可以连续性测试汽车电路系统的线路或部件，连接或者断开状态。
- 当探针接地良好时，液晶显示屏会显示“0.0Ω”，同时绿色的LED指示灯也会亮起。如果提示音功能已经开启，蜂鸣器会同时发出短提示音。

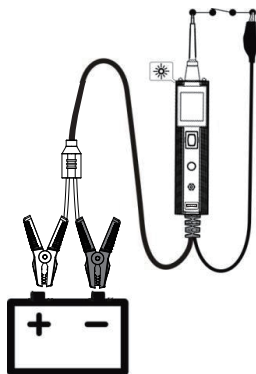

- 在其他情况下，液晶屏将只显示阻值。



- 如果阻值大于200千欧，液晶屏将显示“0L”。

还有另外一种方法可以证明接地还是电瓶的连续性。用电源开关连接供电，如果断路器跳闸，说明此连接是一个良好的低电阻连接。

⚠ 注意

- ▶ 您可以用锋利的探针刺破电线上的绝缘壁，如此您无需断开任何线路便可以测试该电路。

信号电路测试 一旦从汽车电脑中发现故障码，并且意识到该故障码是由于汽车电路传感器系统所导致，以下举例的方法可以快速地测试并验证该故障码。

例如，您怀疑车辆的M.A.P.传感器电路出现故障。那么，可通过下列方式逐步测试：

- 将设备设置到交流电压模式，用探针接触汽车底盘或接地辅助线。
- 连接真空泵与M.A.P.传感器。
- 将探针接触到M.A.P.传感器正极，并观察液晶显示屏，正常情况下显示内容应为正弦波形。
- 启用真空泵。
- 释放真空泵并观察液晶屏读数。

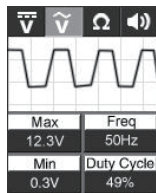

- 若液晶显示屏显示波形异常，即该传感器有故障。

激活手中部件

- 当设备处于直流电压模式时，将探针接触接地辅助线，您可以立即激活手中部件，从而测试它们的功能。
- 连接接地辅助线至部件的负极或接地端测试，然后将探针接触至部件的正极，绿色LED指示灯将会亮起，说明部件的连续性测试通过。
- 在看着LED指示灯的同时，迅速向前按压并释放电源开关。如果绿色LED灯熄灭，红色LED灯亮起，表明需要更进一步的激活方式。用力向前按压电源开关时不要松开以便给部件供电。随着用力按压电源开关，电流将会从电瓶正极流入探针，通过探针流入

部件的正极，流入部件后通过接地辅助引线流出部件，最后流回至汽车电瓶负极。

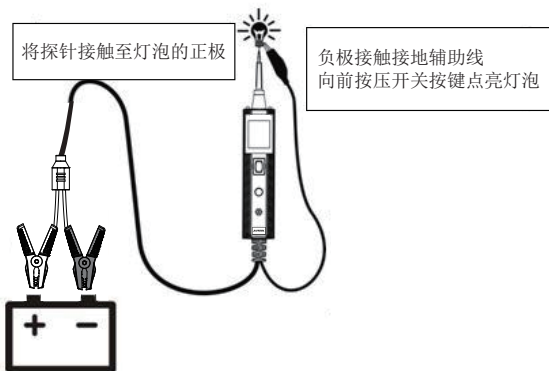

若绿色LED瞬间熄灭，或者断路器跳闸，说明本产品过载，此种现象可能由如下原因导致：

- 您直接将探针接触到负极或地线；
- 您所测试的部件存在短路情况；
- 该部件是高电流部件（如启动马达等）。

如果断路器跳闸，其冷却15秒后便会自动复位。

测试拖车灯和连接状态

- 当设备处于直流电压模式时，将接地辅助线连接至拖车灯的地线，将探针插入OBD脚位显示及时电压。通过此方法可以检查连接器和拖车灯的功能和方向。如果断路器跳闸，其冷却15秒后便会自动复位；也支持手动复位，只需按下复位按钮，直至其卡入到位即可。

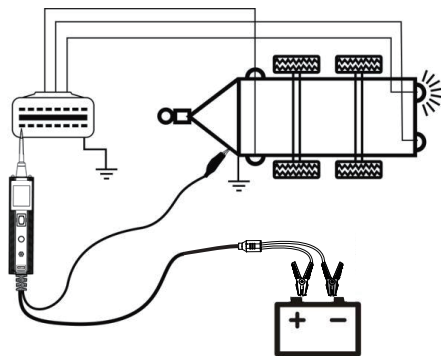

激活车上部件

当设备处于直流电压模式时，将探针接触至部件正极，绿色LED指示灯将会亮起，说明此线路是连续性的接地。在看着LED指示灯的同时，迅速向前按压并释放电源开关，如果绿色LED灯熄灭，红色LED灯亮起，表明需要更进一步的激活方式。（如图）如果绿色LED灯熄灭的瞬间，断路器跳闸，说明本产品过载，此种现象可能由如下原因导致：

- 您直接将探针接触到地线；
- 您所测试的部件存在短路情况；
- 该部件是高电流部件（如启动马达等）。

如果断路器跳闸，其冷却15秒后便会自动复位。

⚠ 警告

- ▶ 随意施加电压到车辆电路会引起车辆电子部件的损坏，因此建议在测试时请参考车辆制造商的原理图和诊断程序。

⚠ 注意

- ▶ 在设备供电时，您可以采用先按压开关，然后再将探针接触组件的方法来延长开关的使用寿命。

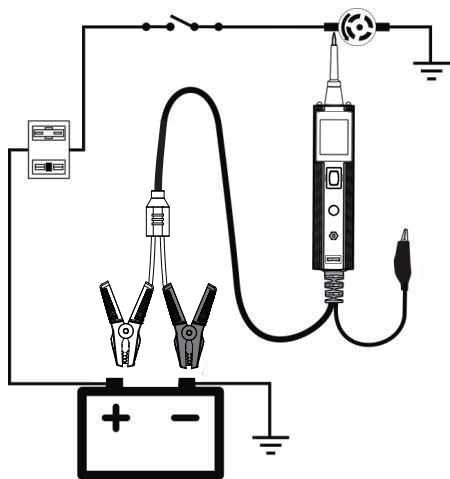

激活部件/ 接地

当设备处于直流电压模式时，将探针接触至部件负极，红色LED指示灯将会亮起。在看着红色LED指示灯的同时，迅速向前按压并释放电源开关，如果红色LED灯熄灭，绿色LED灯亮起，表明需要更进一步的激活方式。（如图）如果绿色LED灯熄灭的瞬间，断路器跳闸，说明本产品过载，此种现象可能由如下原因导致：

- 您直接将探针接触到正极；
- 您所测试的部件存在短路情况；
- 该部件是高电流部件（如启动马达等）。

如果断路器跳闸，其冷却15秒后便会自动复位。

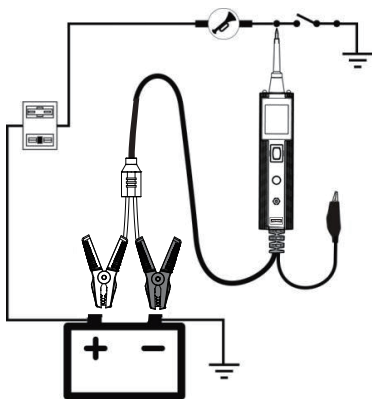

⚠ 注意

- ▶ 使用此功能时, 如果您探测一个被保护的电路并搭上地线, 车辆的保险丝可能熔断或跳闸。

检查地线 不良接触

使用探针探测可疑的地线。

- 看着绿色LED指示灯, 迅速向前按压并释放电源开关, 如果绿色LED灯熄灭, 红色LED灯亮起, 表示该线路不是一条真正地线。
- 如果断路器跳闸, 那么该线路有可能是一条地线。需要注意的是, 高电流部件例如启动马达等也会使断路器跳闸。

追踪和定位 短路电路

在大多数情况下, 短路会表现为一根保险丝熔断或电气保护装置跳闸 (例如断路器跳闸)。追踪和定位短路电路的方法如下:

- 将熔断的保险丝从保险盒中取出;
- 用探针去激活并供给每个保险丝触点电流;
- 断路器跳闸的线路即为短路线路, 注意记录下线路的编号或颜色;

- 尽可能远地跟随导线来追踪线束。

以下为举例示范：

- 如果您正在追踪刹车灯的短路线路，首先线束必须穿过导线的门槛，找到该线的颜色或编号并标记它。
- 接着用探针与绝缘处接触，向前按压电源开关以此激活并给线路通电。
- 如果断路器跳闸，表示已经验证了该线路短路，注意剪断该条线路并用探针分别给导线的两端加电，再次使断路器跳闸的一端即为短路端，它将引导您找到短路区域。
- 沿着导线短路的方向不断重复此操作过程，直到您找到短路的准确位置为止。

红绿LED 指示灯

- 当探针电压伏数和电瓶电压伏数符合并在 $\pm 0.8V$ 的误差范围内，红绿LED指示灯将亮起。此额外的信息对技术员的实际操作是十分有帮助的。
- 若您测试的电路电压与供电电源的电压不在 $0.8V$ 的范围内（高出或低于），您将会在液晶显示屏中读取实际的电压伏数，但您不会听到蜂鸣器的响声，也不会看到红色或绿色LED指示灯亮起。这表明您当前所测试的电路电压从电瓶出来后，最少有 $0.8V$ 的电压降压，或您当前所测试的电路电压超过电瓶电压 $0.8V$ 。
- 为了确定电瓶的实际电压，只需移开探针并向前按压电源开关。电瓶电压将会显示在液晶屏上。电瓶实际电压和线路电压的差值就是实际增加或减少的电压。通过此种方法您将可以在不需返回检查电瓶的情况下便可以确定电压的增减值。

规格参数

名称	数值
直流电压测试范围	0~65V +1
交流电压测试范围	0~65V +1
电阻测试范围	0~200K Ω
音频通过时的频率	0Hz~10Khz
断路器电流范围	1~10Amp

测试标准

100%电流	无跳闸
150%电流	1小时内跳闸
200%电流	跳闸3~30秒
300%电流	跳闸0.5~4.0秒

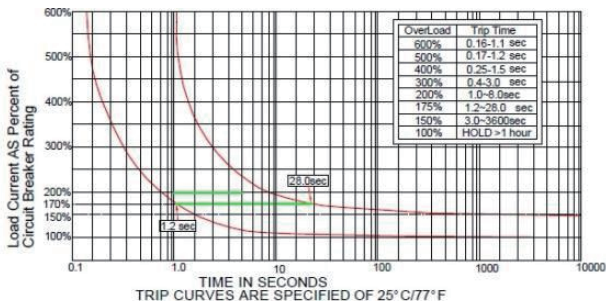

常见问题

产品可以测试汽车电脑和气囊安全吗？

- 本产品的LED指示灯和液晶显示屏使用不超过1毫安的电流，因此当把它用作照明灯或万用表时，进行测试汽车电脑和气囊是安全的。尽管如此，但按压电源开关按钮就存在着另外一种情况。当您向前按压电源开关时，电瓶的全部电流都将流向并储存再探针尖端。本产品有一个良好安全的内置工具，您只需要接触接地辅助线，然后向前按压电源开关，直至断路器跳闸，这将有效防止电流流向探针尖端。另外，本产品支持当做万用表使用。

为何探针没电时，当我向前按压电源开关后红色LED指示灯还不亮？

- 电源开关使用频繁，这是该设备的常见问题之一。开关属于易耗品，需要定期更换。我们已将开关进行简单设计，该开关可以在几秒内取出并更换完毕。总体而言，该设备的电源开关不仅便于更换而且容易购买。
- 您可以从捷代授权经销商处直接购买开关用于更换。

电源开关更换步骤

- 用螺丝刀轻撬取出坏的开关，取出时请小心不要用力过猛。

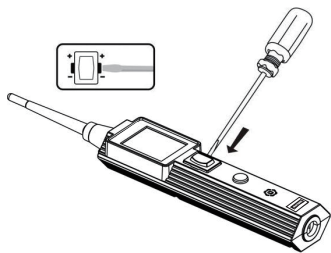

- 确保安装新开关的时候要垂直放入，并按压使开关与外壳齐平。

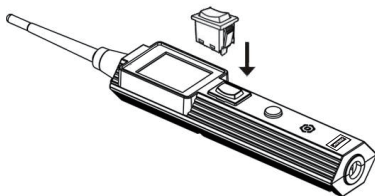

维修保养服务

您所拥有的AUTOOOL产品选用持久耐用的材料，AUTOOOL坚持精益求精的生产工艺，每一件产品出厂都经过35道工序及12次质检工作，从而确保每一件产品都拥有卓越的品质及性能。所以您的AUTOOOL产品值得您定期维护保养，使其将能够长期稳定地工作。

维修保养

维护保养是为了保持产品性能和外观，我们建议您仔细阅读以下产品保养指南：

- 注意不要将产品与粗糙表面摩擦或揉搓产品，特别是钣金外壳。
- 对产品中需要紧固和连接的部位经常进行检查，如发现松动应及时紧固，以保证产品的安全运行。对与各种化学介质接触的产品外部和内部零件要经常进行除锈、喷漆等防腐处理，以提高产品的抗腐蚀能力，延长产品的使用寿命。
- 遵守安全操作规程，不超负荷使用产品。产品的安全防护装置齐全可靠，及时消除不安全因素。电路部分彻底检查，老化电线要及时更换。
- 定期清洗和更换油泵、滤油器等易耗部件；调整各部位配合间隙和更换磨损（已坏）部件清洁时，避免产品接触带腐蚀性的液态物品。
- 不使用时，请将产品存放于干燥的位置。不要将产品存放在高温、潮湿或不通风的地方。

保修服务

AUTOOL主机自客户签收日起享有3年保修期。其所含附件自客户签收日起享有1年保修期。

保修方式

- 根据具体的故障情况对产品进行免费修理或更换；
- 我方保证所有更换的部件、附件或产品都是全新；
- 在客户收到产品90天内出现故障同时提供视频和图片，我方承担运费并免费提供相应配件给客户更换。收到产品超过90天，客户承担相应的费用，我方免费提供配件给客户更换；

以下情况不在免费保修范围：

- 非正规渠道购买AUTOOL的产品；
- 未按产品说明书要求使用和维护造成的损坏；

在AUTOOL，我们为精湛的设计和卓越的服务感到自豪。我们很乐意为您提供更多的支持或服务。

声明

偶然公司保留更改产品设计与规格的权利，届时恕不另行通知。实物外观与颜色可能与说明书中显示的有差别，请以实物为准。我们已尽最大努力力求使书中所有描述准确，但仍难免有不妥之处。如有疑问，请联系经销商或偶然售后服务中心。本公司对产品拥有最终解释权，不承担任何因误解而产生的后果。

退换货服务

退换货

- 如果您对从线上授权购物平台和线下授权经销商所购买的AUTOOL产品不满意，根据《AUTOOL全球销售条款》，您可以自收到产品之日起七日内退货；或者在产品交付之日起的30日内调换等值的其他产品。
- 退回及调换的产品必须处于完全可销售状态，并附上相关销售单单据，所有相关配件、纸质发票（如有）。
- AUTOOL将会对寄回退货的商品进行检查，以确保其处于完好无损的状态并且符合条件，相关条件详情请参阅《AUTOOL全球销售条款》。任何未通过检查的商品将退还给您，您将不会获得商品退款。
- 您可以通过客户服务中心或AUTOOL授权经销商调换产品；退换货原则为从哪里购买，就从哪里退换货。如果您退换货遇见困难或者阻碍，请联系AUTOOL客户服务中心。通过客户服务中心退换货时，我们建议您通过下面的方式进行：

中国区域致电	400-032-0988 / 18929303778
售后微信号	18929303778
海外区域致电	+86 0755 23304822
E-mail	aftersale@autooltech.com
Facebook	https://www.facebook.com/autool.vip
YouTube	https://www.youtube.com/c/autooltech

- 如您的退换货得到确认，您将收到确认信息和邮件。